



**AUTO TIP CHANGER
SH-C-F
USER MANUAL**

Please read this manual before use.



ATTENTION TO SAFETY

- Please be sure to read “ATTENTION TO SAFETY” before using SH-C-F.



This product is intended only for the exchanging of specified electrodes. This product is not to be used in any manner other than that which is specified within this manual. We will not be held responsible for damage or injury caused as a result of misuse of this product.















SYMBOLS







- ※ The following symbols “Caution” and “Notice,” are used to indicate possible hazards and to prevent their occurrence.

 Caution	Be careful to follow directions as specified, as an error could lead to possible injury or death.
 Notice	Be careful to follow directions as specified, as an error could lead to malfunction and serious damage.

- ※ The following symbols are explained below.

	This symbol indicates operations that should not be done.
	This symbol indicates operations that should be done.

 Caution	
<p> Absolutely never disassemble or reconfigure this machine or its parts.</p> <ul style="list-style-type: none"> ○ This could result in operation malfunction, ignition, or injury. 	<p> Do not insert a finger or hand into gear opening while in operation.</p> <ul style="list-style-type: none"> ○ This will result in serious injury.
<p> Avoid as much contact with water as possible.</p> <ul style="list-style-type: none"> ○ This could result in operation malfunction (short), electrical shock or ignition. 	<p> Do not insert metallic articles such as a pins or needles in gear or terminal box opening.</p> <ul style="list-style-type: none"> ○ This could result in operation malfunction or electrical shock.
<p> Be sure to switch off the power supply, when removing or repairing wiring.</p> <ul style="list-style-type: none"> ○ Will cause electrical shock. 	<p> Be sure that spatter does cover any wiring.</p> <ul style="list-style-type: none"> ○ This will prevent the melting of wire membrane and a potential shock hazard.
<p> Remove the spatter which covers the tip dresser periodically.</p> <ul style="list-style-type: none"> ○ Spatter build-up can cause operation malfunction or ignition resulting in injury. 	<p> Do not use acidic or chlorine detergents for maintenance purposes.</p> <ul style="list-style-type: none"> ○ Poisonous gas may be generated from the detergents, causing a possible health risk.
<p> Remove any oil that may accumulate on the tip dresser.</p> <ul style="list-style-type: none"> ○ Spatter could cause ignition and possible Injury. 	<p> Do not use voltage other than that which is specified.</p> <ul style="list-style-type: none"> ○ Excess heat could cause operation malfunction and ignition.
<p> Be sure wire from power supply is of correct capacity. (10A/1unit)</p> <ul style="list-style-type: none"> ○ Incorrect wiring could result in operation malfunction or ignition 	<p> Use correctly sized wiring. (2 sq inches or more)</p> <ul style="list-style-type: none"> ○ Incorrect wiring could result in operation malfunction or ignition
<p> Do not allow power supply wiring to become damaged.</p> <ul style="list-style-type: none"> ○ Wiring damage could result in operation malfunction and ignition. 	

 Notice	
<p> Ffirmly fix tip changer to stand.</p> <ul style="list-style-type: none"> ○ If the Tip Changer is not fixed tightly in operation, operational failures and other problems could occur. 	<p> Be sure that the motor is not locked up.</p> <ul style="list-style-type: none"> ○ This could result in overheating and possible ignition.
<p> Do not use any parts other than that which is intended and specified.</p> <ul style="list-style-type: none"> ○ Use of an unspecified cutter or holder, could result in damage. 	<p> Do not install near the thermal generation source of the welding machine.</p> <ul style="list-style-type: none"> ○ This could cause trouble and accidents.
<p> Do not install between a welding machine and a transformer.</p> <ul style="list-style-type: none"> ○ Strong magnetic forces and heat can be dangerous and possibly cause malfunctions or ignition. 	

INDEX

AUTO TIP CHANGER SPECIFICATIONS	1
FEATURES	1
WIRING PRECAUTIONS	2
LAYOUT OF COMPONENTS	3
WIRING TO CONTROL BOX	3
TIP SETTER SPECIFICATIONS	5
STAND SPECIFICATIONS	5
GUNS TO BE USED WITH REMOVER	7
CAUTIONS AND CONFIRMATIONS BEFORE OPERATION	8
REPLACEMENT PROCESS	8
REPLACEMENT PROCESS WITH ONE LIMIT SWITCH	13
CAUTIONS FOR TIP REPLACEMENT	17
FLOW CHART FOR AUTO TIP REMOVER	21
ABNORMALITY AND COUNTERMEASURES	22
CONSUMPTION ARTICLES	25
REGULARLY MAINTENANCED PARTS	27
SH-C-F WITH STANDARD STAND	28
SH-C-F OUTER DIMENSIONS	29
TIP SETTER OUTER DIMENSIONS	30

AUTO TIP CHANGER SPECIFICATIONS

MODEL	POWER (V)	FREQUENCY (Hz)	CURRENT (A)	RPM		OUTPUT (W)	RATED TIME	MASS (kg)	OTHERS
				REMOVER	REMOVER				
SH-C-F (1:60)	380	50	0.31	23.5	4.0	100	CONTINUITY	28	CORRESPOND TO CE, CUL BY CHANGING TIME MOTOR
	400	50	0.31	23.7	4.1				
	400	60	0.28	28.3	3.4				
	440	60	0.28	28.7	3.4				

AUTO TIP CHANGER

MODEL: SH-C-F

POWER SOURCE: 3 Phase AC380V/AC400V/AC440V

Compressed air for error break cylinder 0.5(MPa)

CAP TIP FOR CHANGER: 16dia Concentric

ESTIMATED REMOVAL TIME: 6-8 (sec)(Minimum time 50Hz 6sec, 60Hz 5sec)

COLOR: 7.5YR 7.5/9.5

FEATURES

1. Floating mechanism decreases stress of loading gun for removal.
2. Available for use with voltages between 200 and 480.
3. Powder coated finish (7.5YR 7.5/9.5)
4. Dresser motor and terminal box conform to IEC standard; IP54 conformity
5. Design based on CE and CUL standar

WIRING PRECAUTIONS

<TERMINAL BOX>

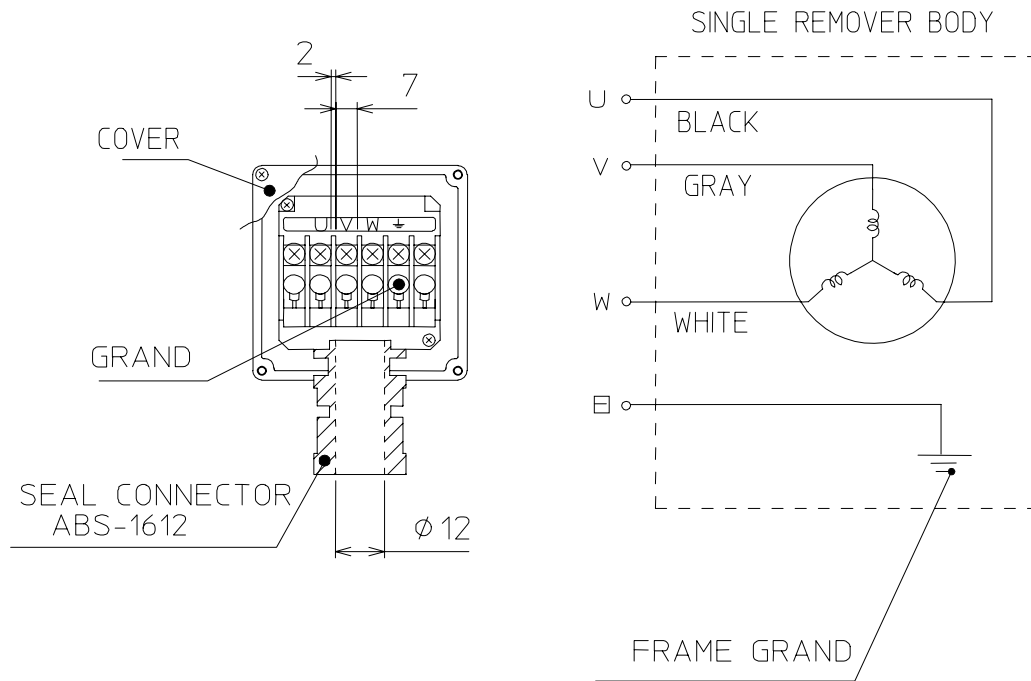

- Use 2sq inch wire (AWG Gauge NO. 14)
- When wiring the power cord, use a solder-less terminal; R-type (2-4S)
- Do not wire while the switch is on. (Be sure to turn the switch off.)
- Please take the cable's slack into consideration when wiring because the floating mechanism is used with the SH-C-F.
- The operator should have certification as an approved electrical worker.
- It is essential to make a ring with the cable near the tip remover. This will allow for additional cushioning.

LAYOUT OF COMPONENT PARTS

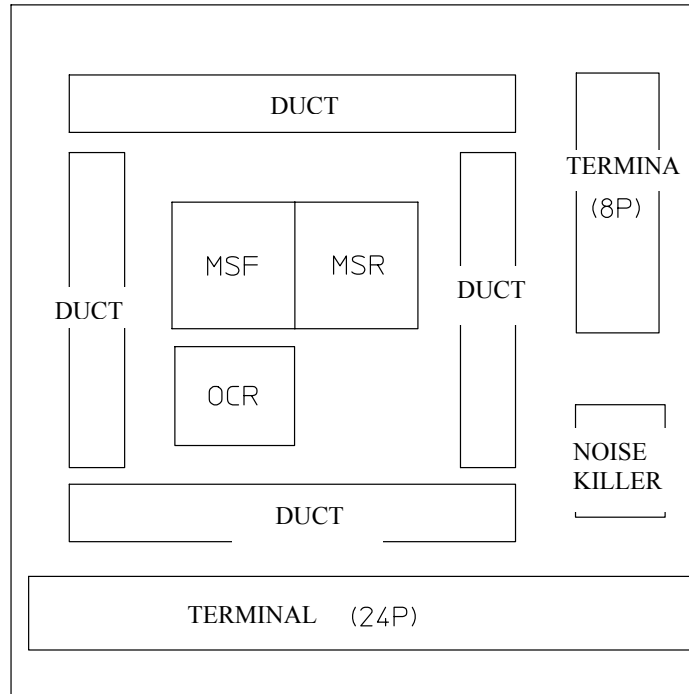

POWER SOURCE (AC400V) CIRCUIT DIAGRAM

WIRING TO CONTROL BOX

CONTROL BOX CIRCUIT DIAGRAM (DC24)

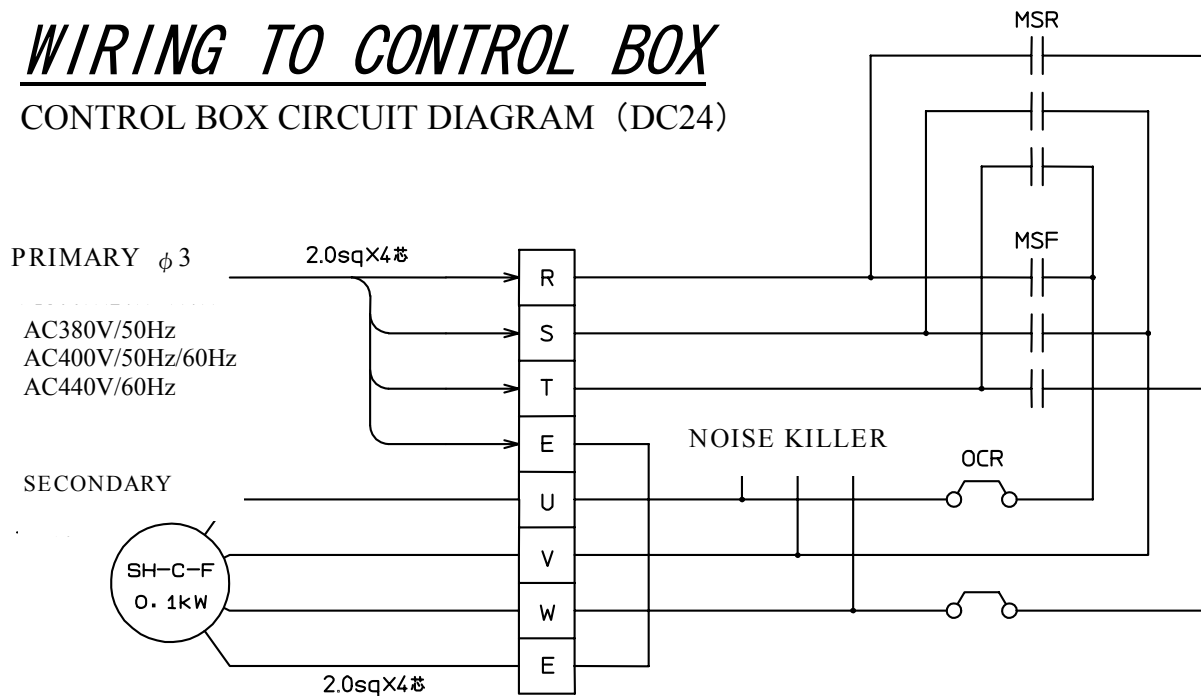

Circuit Diagram from the terminal box to the control box

WIRING DIAGRAM (REFERENCE WIRING)

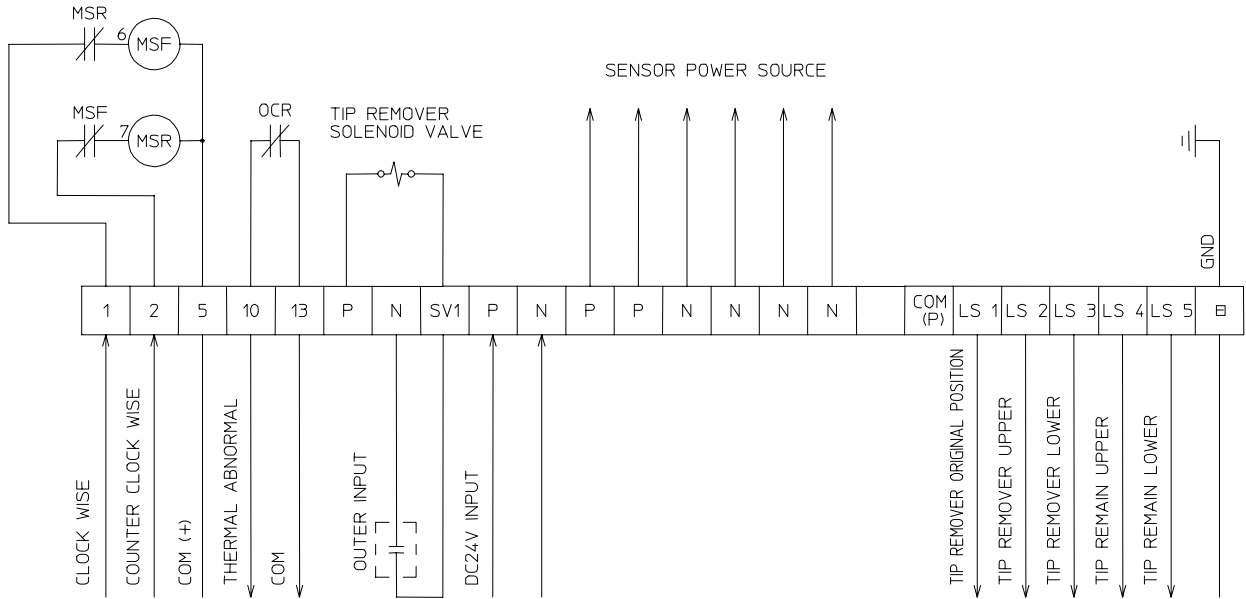

CIRCUIT DIGRAM FOR ATC (REFERENCE WIRING)

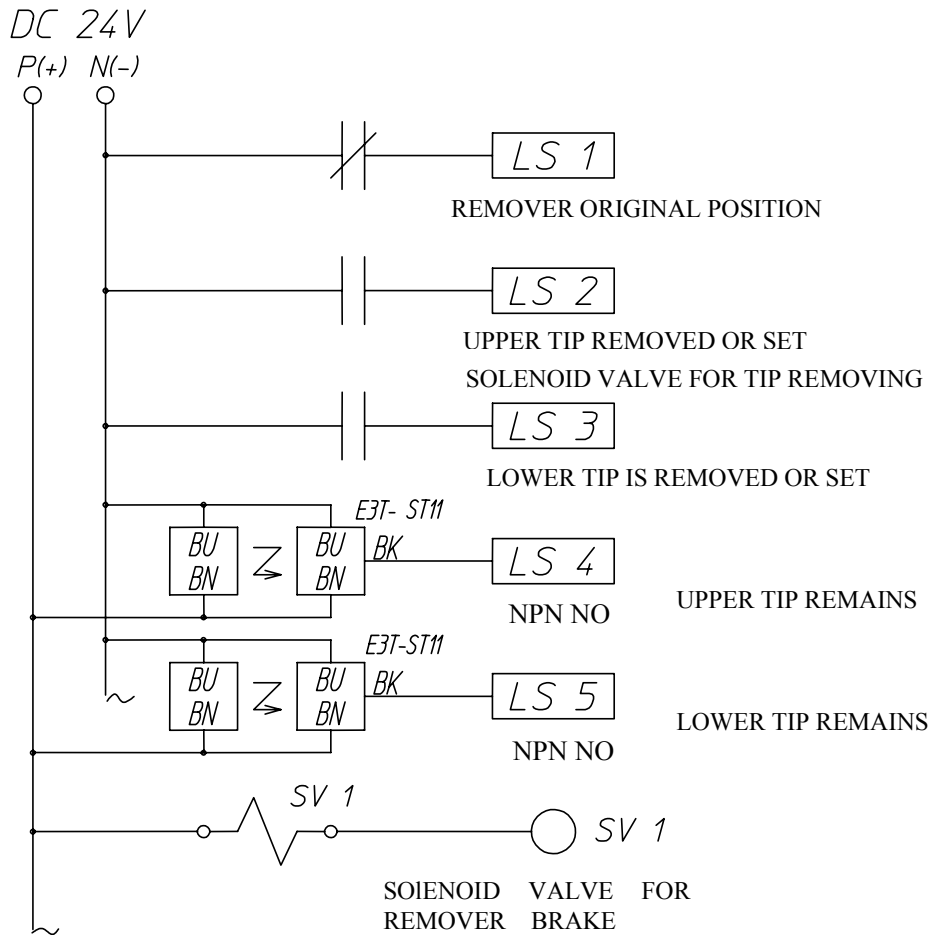

Drawing 1

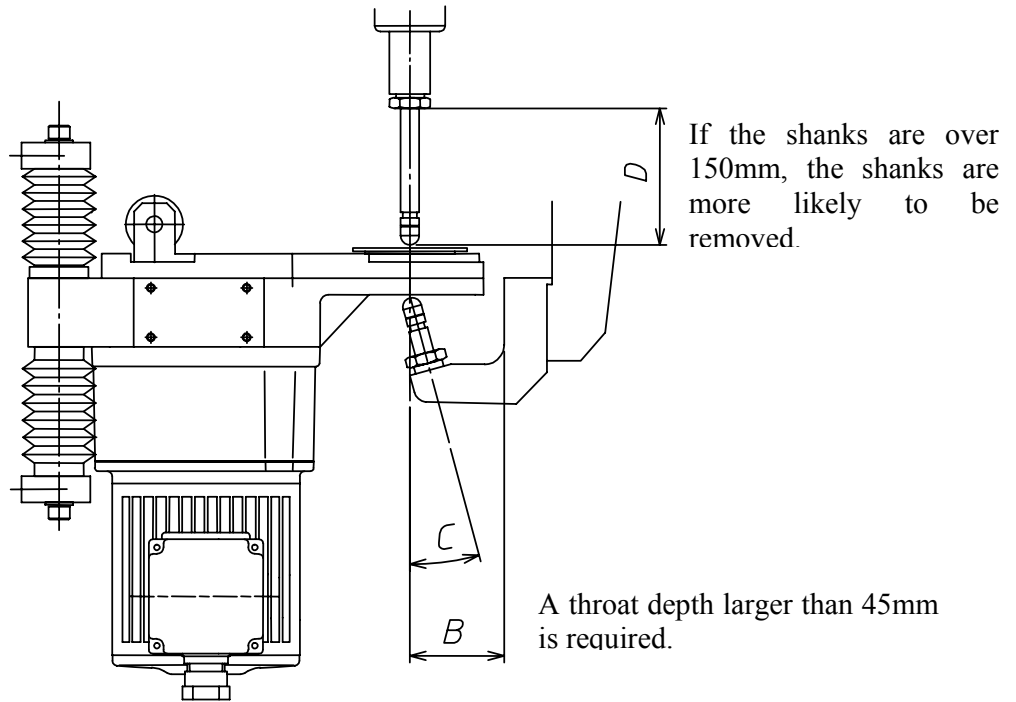

Drawing 2

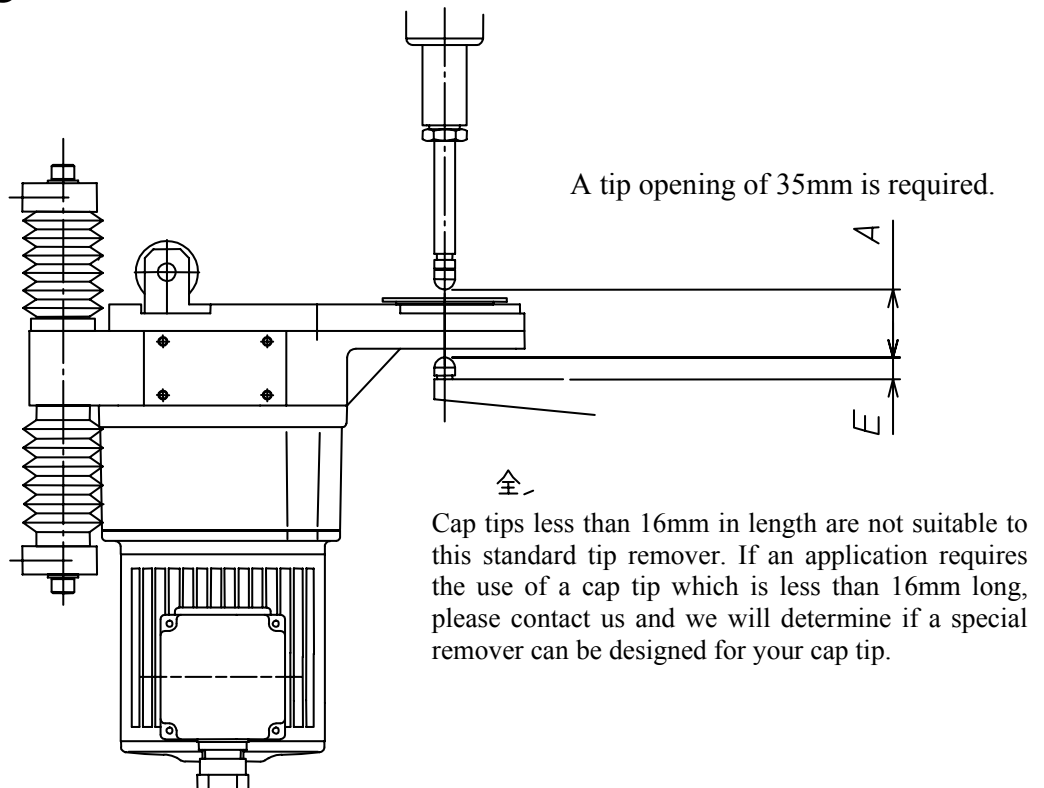

Guns to be used with Tip Remover

An applicable cap tip is a concentric 16 dia.

(Applicable to both X-guns and C-guns; See figure 1 and 2)

1. “A” dimension: 34mm or more. If “A” dimension is less than 34mm, it cannot be removed because it may contact on the dresser gear box.

2. B dimension: 46mm or more.
*If B dimension is less than 46mm, it cannot be removed because it may make contact with the remover.

3. A concentric tip with an angled arm (Angle C) should be less than 15 degrees.
*If using eccentric cap tips, please contact us.

4. Base tip type requires a specific blade and replacement is impossible.

5. Please choose a remover suitable to the cap tip.

Cautions and Confirmations before operation

1. Confirm the specifications again. (voltage, option, etc...)
2. Install the remover in a place where the operator cannot touch it directly during the operation.
3. Make sure the installing bolts of the remover and stand are tightened firmly and also the anchor bolts of the stand are firmly affixed to the floor.
4. When connecting the wires to the remover, operation procedures must be followed with the electric construction standard and also make sure that it is protected from cooling water or spatter.
5. When teaching, be sure that the remover nails match the cap tip’s outer dimension.

REPLACEMENT PROCESS (WITH THREE LIMIT SWITCHES)

1. Start removing. “Note.8”
↓
2. Turn off the welding power.
↓
3. Force discharge of the cooling water or stop water supply. “Note.1”
↓
4. Confirm that the tip remains. “Note.2”
↓
5. Rotate clock-wise in tip removing direction (Stop for 2 seconds)
↓
6. Robot moves to the tip setting position. “Note 7”
↓

7. Remove a cap tip (either upper or lower)
Remover will rotate in tip removing direction. (Clock-wise) “Note 6”
One second later, move the robot 5mm from tip removing position. Keep the position.
↓
8. Set the operation timer. Robot start moving after the time taken by removing as it shown in this manual. “Note 8”
↓
9. Robot moves to cap tip remove/put on position.
↓
10. Motor stop.
↓
11. Confirm the cap tip is removed by limit sensor.
↓
12. Rotate to tip discharging direction (Counter clockwise) “Note 6”
↓
13. Remover stops rotate to discharging direction after 2 seconds.
↓
14. Robot move to the tip set position. (Put the cap tip on the side that was removed at 6)
↓
15. Robot sets tip by gun pressure. “Note 3”
↓
16. Robot confirms tip setting (By tip removal/setting limit sensor) “Note 4”
↓
17. Robot gun pressurizes. (Avoid to fall the cap tip while changing the other side)
↓
18. Robot moves to the tip setting position.
↓
19. Remove the cap tip on the other side. Rotate to tip removal direction.
“Note 6”
Robot moves 5mm to tip removal direction after 1 second. Keep the position.
↓
20. Set the operation timer. Robot start moving after the time taken by removing as it shown in this manual. “Note 8”
↓
21. Robot moves to tip removal/setting position. “Note 7”
↓
22. Motor stop.
↓
23. Confirm the limit sensor switch for coming off/setting tip. “Note 4”
↓
24. Rotate tip discharging direction. “Note 6”
↓
25. Stop rotation after 2 seconds.
↓
26. Robot move to the tip setting position (Set the cap tip on the side removed at 20)
↓
27. Robot sets the cap tip by gun pressure. “Note 3”
↓
28. Confirm the limit sensor switch for coming off/setting tip. “Note 4”
↓
29. Robot gun pressurizes. “Note 5”
↓
30. Supply the cooling water (supply water).
↓
31. Turn on the welding power.
↓
32. Tip exchange is finished.

NOTE 1

*When you need to stop the water supply, do it near the electrode of the welding gun. Residual water in a long laying pipe can cause damage and poor operating conditions.

*If the robot has a program using the emergency stop when the cooling water stops. Please disable when using the auto tip remover.

NOTE 2

*Check the presence of tip-by-tip remaining sensor and start the operation.

(When the LS4 • LS5 in on, there are no remaining cap tips. Do not operate the remover in the situation)

NOTE 3

*Gun pressure for setting the cap tip should be less than 2,500 [N] (250kgf)

NOTE 4

*Use the tip removal limit sensor. It is available separately. Choose the most efficient operating method.

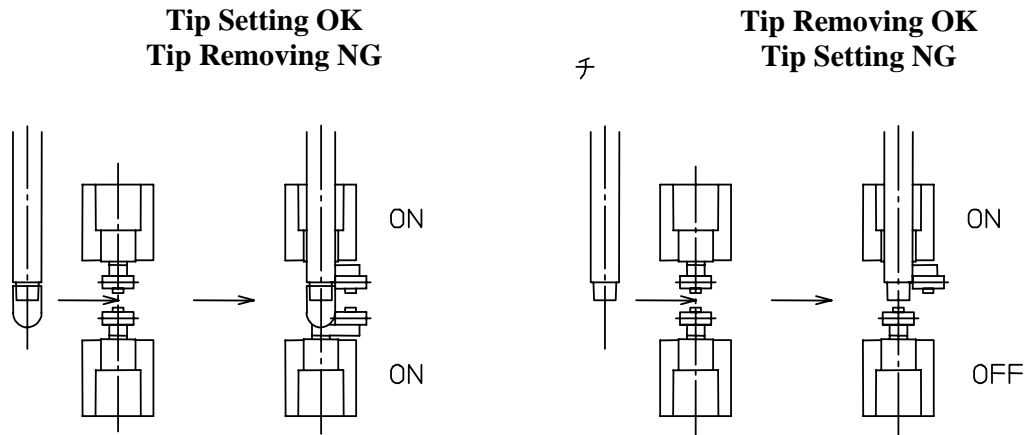

NOTE 5

*In note 3, when the tip setting is done in lower pressure, revert to the original pressure, close the gun, and pressurize again. Especially if using a new shank, the tip may come off more easily.

NOTE 6

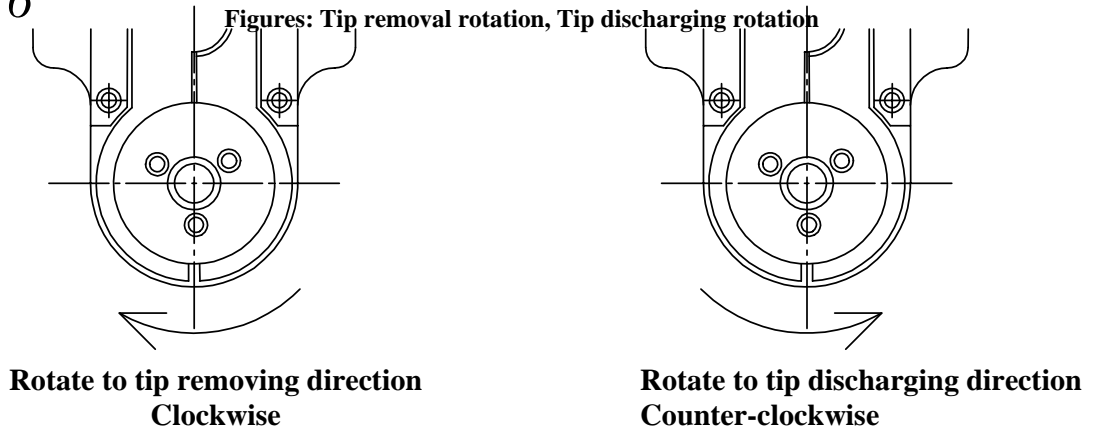

NOTE 7

Figures: Tip Remover nail in relation to the position of the tip. (16dia cap)

REMOVING PLACEMENT

UPPER REMOVING PLACEMENT

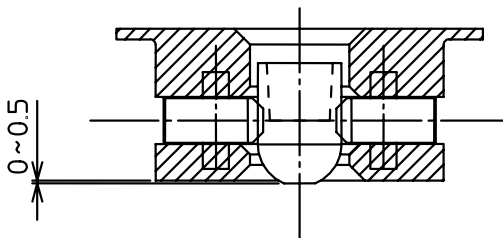

LOWER REMOVING PLACEMENT

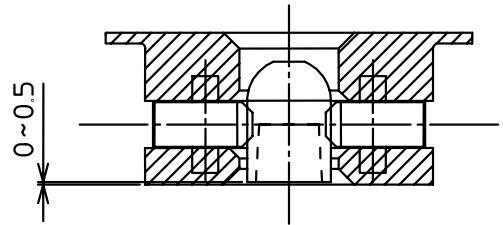

REMOVING PLACE WITH TEACHING JIG

UPPER REMOVING PLACEMENT

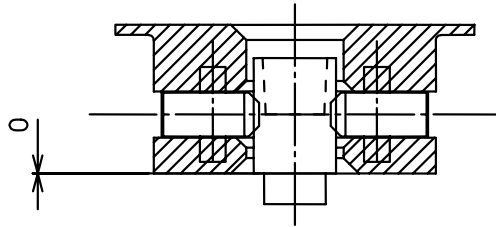

LOWER REMOVING PLACEMENT

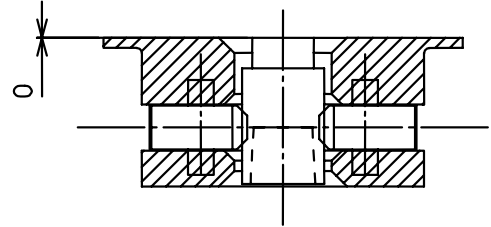

*Do not remove the teaching jig with the remover. It will damage the nail.

NOTE 8

*A limit switch for the original position confirmation, is to work in the space from the tip exchange start, until its completion.

*In the case of an original position error, stop the tip exchange process and address the abnormality in the tip exchange process.

REPLACEMENT PROCESS (WITH ONE LIMIT SWITCH)

1. Start removing. "Note.8"
↓
2. Turn off the welding power.
↓
3. Turn on the tip remover power.
↓
4. Force discharge of the cooling water or stop water supply. "Note.1"
↓
5. Confirm the tip is remained. "Note.2"
↓
6. Rotate to tip removing direction (Stop for 2 seconds)
↓
7. Robot moves to the tip setting position. "Note 7"
↓
8. Remove the cap tip (Upper or Lower)
Rotate removing direction (Clockwise) to start removing. "Note 6"
Move the robot 5mm to removing direction after 1 second. Keep the position.
↓
9. Set the operation timer. Robot starts moving after the time taken by removing as it is shown in this manual. "Note 8"
↓
10. Robot moves to tip setting position.
Confirm the tip setting by using a limit sensor

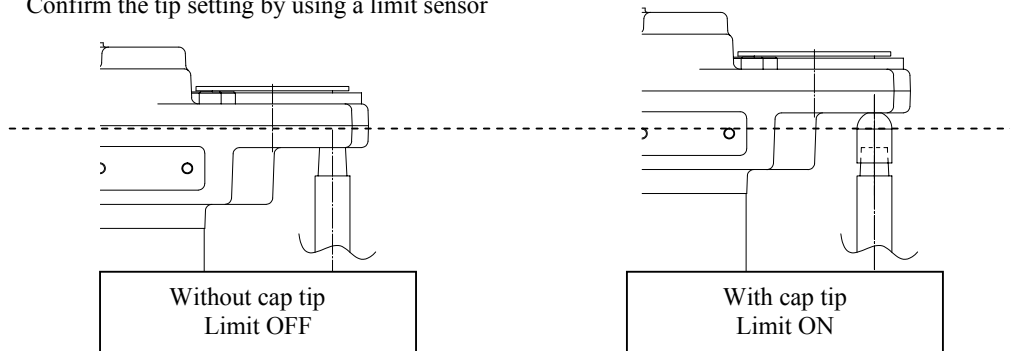

- ↓
11. Move the robot to setting or check position.
↓
12. Confirm with the limit sensor.
↓
13. Rotate to tip discharging direction. "Note 6"
↓
14. Stop rotation after 2 seconds.
↓
15. Move the robot to tip setting position (set the cap tip on the side removed at step 6)
↓
16. Robot sets tip by gun pressure. "Note 3"
↓
- ↓

17. Robot confirms the tip setting (By tip removal/setting limit sensor) ”Note 4”
↓
18. Robot gun pressurizes. (Avoid falling the cap tip when putting the other side on)
↓
19. Robot moves to tip removing position.
↓
20. Remove the other side. Rotate to the removal direction. “Note 6”
Rotate 5mm to tip removing direction after 1 second. Keep the position.
↓
21. Set operation timer. Robot start moving after the time taken by removing as it shown
in this manual. “Note 8”
↓
22. Move to the robot tip setting or check position.
↓
23. Stop motor.
↓
24. Confirm the limit sensor switch for coming off. “Note 4”
↓
25. Rotate to tip discharging direction. “Note 6”
↓
26. Stop rotation after 2 seconds.
↓
27. Robot moves to tip setting position. (set the cap tip on the side removed at step 20)
↓
28. Robot sets tip by gun pressure. “Note 3”
↓
29. Confirm the limit sensor switch for setting tip. “Note 4”
↓
30. Turn off the tip removing break.
↓
31. Robot gun pressure. “Note 5”
↓
32. Supply the cooling water.
↓
33. Turn on the welding power.
↓
34. Tip exchange is finished.

NOTE 1

*When you need to stop the water supply, do it near the electrode of welding gun. Residual water in A long laying pipe will cause the inside line stained or other troubles. Please look at “Auto tip remover installation manual for the process to stop the cooling water.

*If your robot has a program with emergency stop when the cooling water stops, please disenable when using the auto tip remover.

NOTE 2

*Check the presence of tip-by-tip remaining sensor and start the operation.

(When the LS4 • LS5 in on, there are no remaining cap tips. Do not operate the remover in the situation)

NOTE 3

*Gun pressure for setting the cap tip should be less than 2,500 [N] (250 kgf)

NOTE 4

*Use the tip removal limit sensor. It is available to equip it separately. Choose the most efficient operating method.

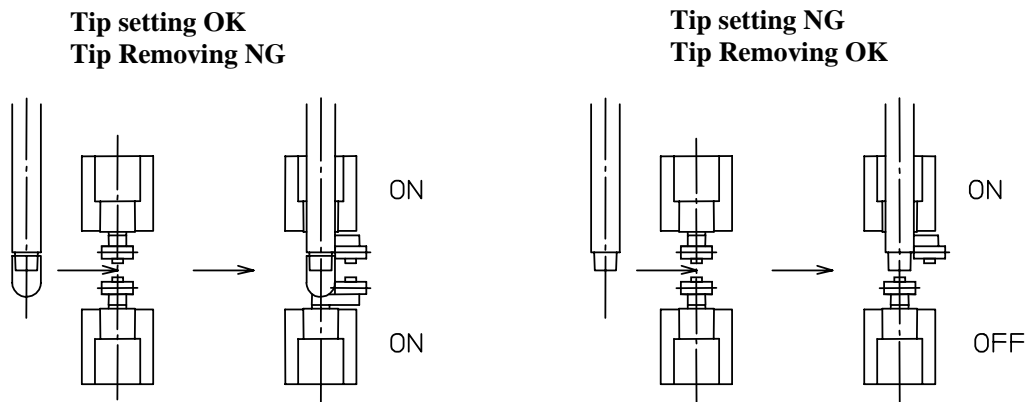

Γ 1

Tip Removing OK
Tip setting NG
Without cap tip
Limit sensor off

Tip Removing NG
Tip Setting OK
With cap tip
Limit sensor on

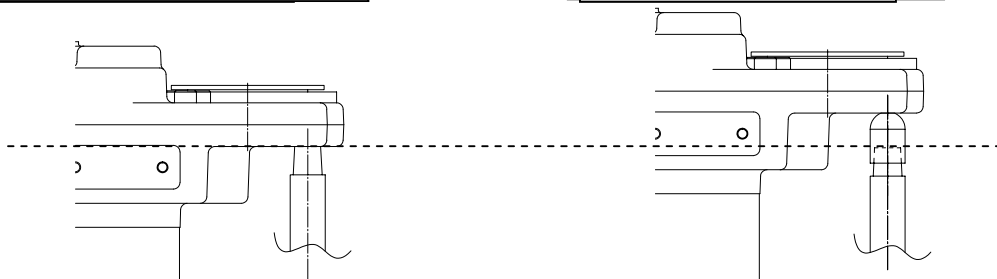

NOTE 5

*In note 3, when the tip setting is done in lower pressure, revert to the original pressure, close the gun, and pressurize again. If using a new shank, the tip may come off more easily.

NOTE 6

Figures: Tip removal rotation, Tip discharging rotation

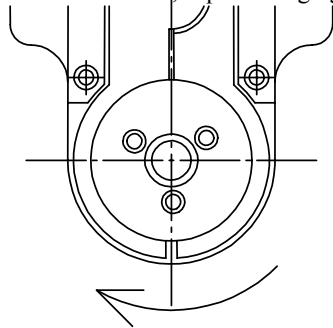

**Rotate to tip removing direction
Clockwise**

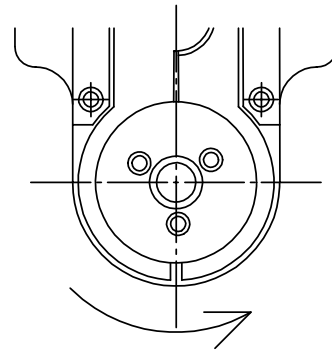

**Rotate to tip discharging direction
Counter-clockwise**

NOTE 7

- Tip Remover nail related to the position of the tip. (In case of 16 dia)

TIP REMOVING PLACEMENT

UPPER REMOVING PLACEMENT

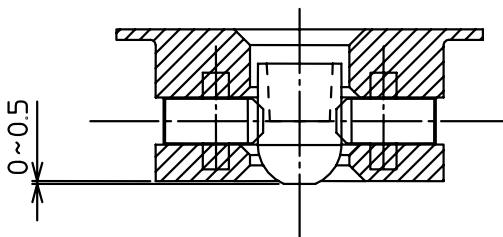

LOWER REMOVING PLACEMENT

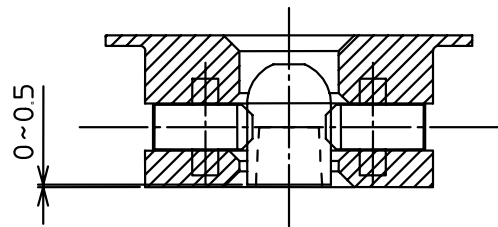

TIP REMOVING POSITION WITH TEACHING JIG

UPPER TIP REMOVING

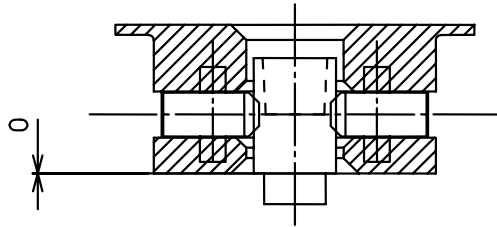

LOWER TIP REMOVING

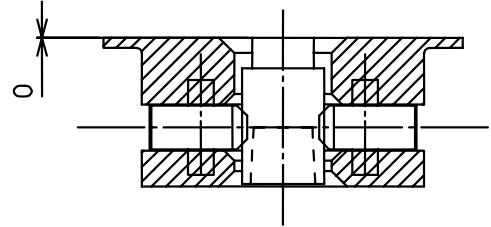

*Do not remove the teaching jig with the remover. It will damage the nail.

NOTE 8

*A limit switch for the original position confirmation is to work in the space from the tip exchange start to the completion.

*In the case of an original position error, stop the tip exchange process and address the abnormality in the tip exchange process.

CAUTION FOR TIP REPLACEMENT

*Please do not use tip remover for any other purpose and avoid empty operation.

*To remove the tip: Fasten the nails around the electrode and remove it as described within.

*This manual describes the removal of 16x23mm cap. Contact our engineering department for tip removal of another style of cap. Some tips may not be removed with this machine.

*We recommend the cylindrical tip. Don't use the polygonal, one side lacked, or deformed tip as below. These shapes will cause damage to the removing nails.

Polygonal

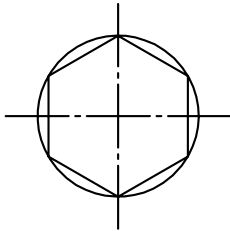

One Side Lacked

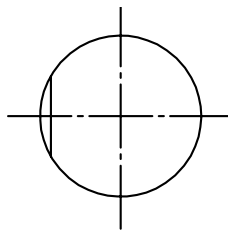

Deformed

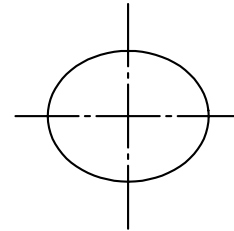

*Install the electrode into the of tip remover while the nails are inside. If you insert the electrode while the nails are outside, it will cause damage to the nails and possibly the remover.

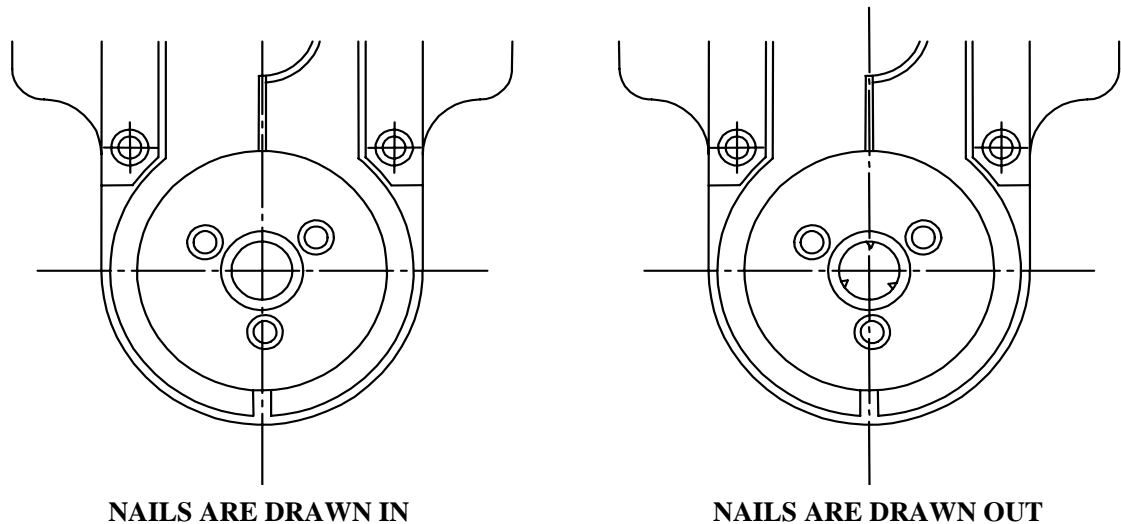

**Do not put fingers into the remover as to prevent any injury!_*

REPLACEMENT ERRORS

Errors can be indicated by setting the sensor or limit switch errors through the robot PLC.

1. Tip remover positional trouble. (LS1 signal off)

* If a previously removed cap is stuck in the remover, the robot shank should push the cap through upon next removal attempt...If this does not occur, an error signal will occur.

**Please stop robot and remover as soon as PLC receives error signal.

2. Tip removing trouble. (When PLC receives both LS2 and LS3 signals after tip removal)

3. Tip setting trouble. (When PLC gets just one signal from LS2 or LS3) tip set has failed.

*Check cap tip magazine to ensure that caps exist and are in correct loading position.

Tip Setter

*Because this part of the machine is not water proof, install it as far away from water or welding spatter as possible.

*Clean it at regular intervals to prevent stains from adhering in the tip cartridge. This can cause malfunctions while tip feeding.

*Clean/Wipe the lens of tip remaining sensor regularly.

*The cartridge for upper and lower are different. Be sure to set the cartridge to the correct setter as the drawings indicate.

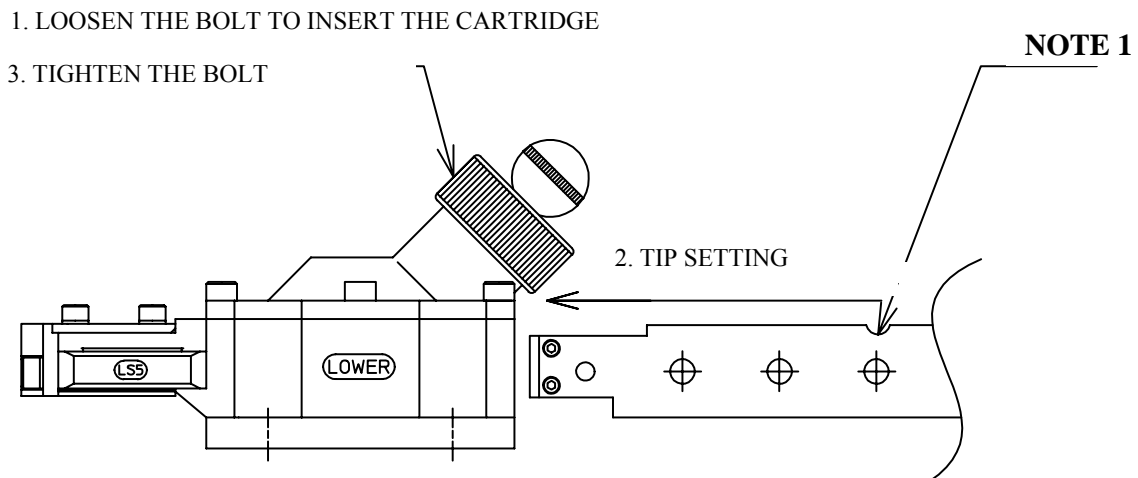
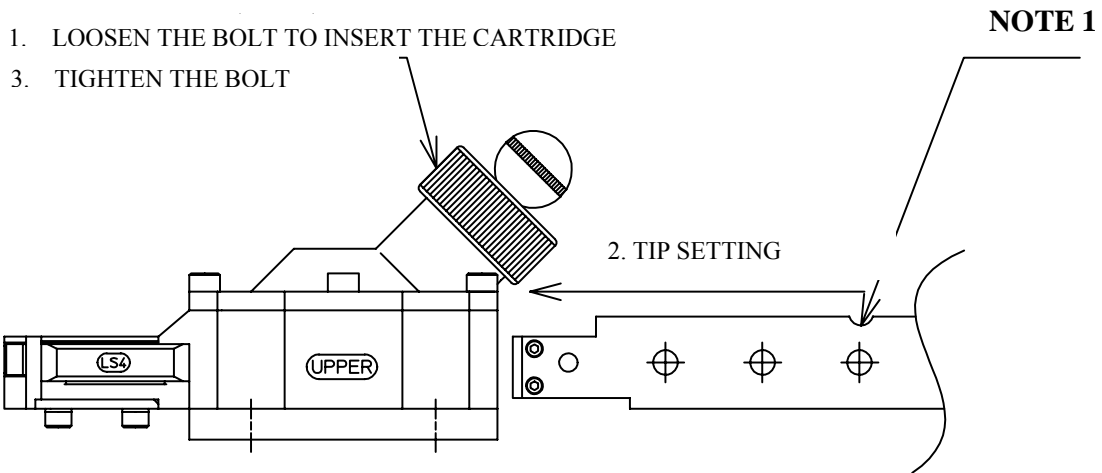

Cartridge mark should come to the bolt side.

Other Attentions

This machine is designed to be used with female cap tips, be aware of the angle of the male taper of the shank. Also when you use a new shank, be sure that tip does not drop off because of a loose fitting taper.

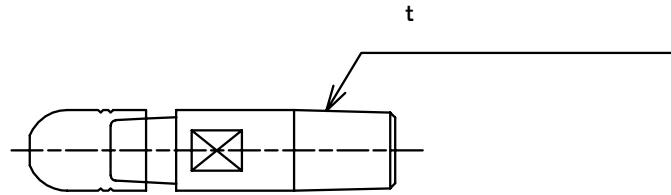

*Male tapered part only is processed by beryllium copper 25 alloys.

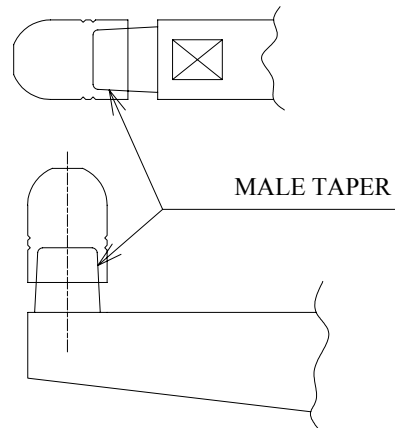

*Use a male taper with material consisting of beryllium copper 25 alloys or its equivalent.

We have many reasonable (lower cost) consumption articles, such as Tip Base type, for example, whose tapered part only is processed or re-processed by beryllium Copper 25 alloys. We are ready to carry out your orders. Please do not hesitate to contact us.

FLOW CHART FOR AUTO TIP REMOVER

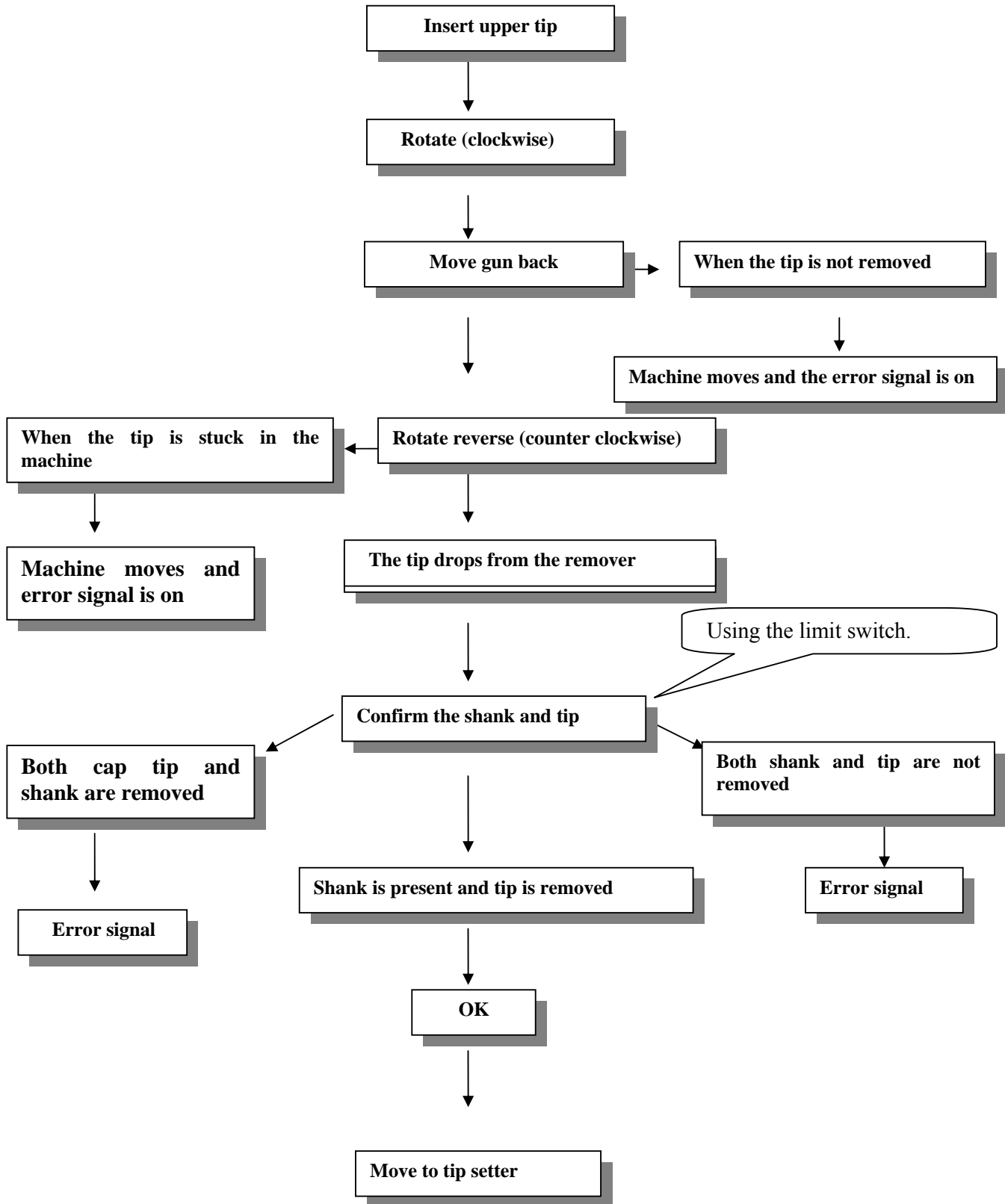

Abnormality and Countermeasures

Issue: Unable to remove the tip.

Countermeasures:

1. Is the remover turning in the correct direction? Tip cannot be removed if the direction of the rotation is incorrect.
2. Is the cylinder brake working? This machine clamps a tip by power of a brake. This brake is adapted to a one way direction pulled cylinder, and a brake works with solenoid controlled pilot valves. Check cylinder for damage, and confirm that the air pressure is correct. (0.5 MPa)
3. Can the three removing nails be seen when the remover is rotating in the tip removing direction?
When the 3 nails cannot be seen:
 - A. There might be dust or chips around the nail that make the nail difficult to move.
 - B. There might be dust or chips stuck in the break.
 - C. There may be oil on the brake and the brake is slipping.

*In case of situation “A,” please remove the brake and the cover, and wipe clean the nails so that they are able to move smoothly. While reinstalling the nails, take notice to the direction of the nails. While reinstalling, please be careful that oil does not adhere to the friction surfaces of the brake and cover.

In case of situations “B.” and “C.,” please remove the brake and wipe clean any debris or oil that may adhere to the friction surfaces of the brake or the cover. While reinstalling, please be careful that dust and oil do not adhere to the friction surfaces of the brake and cover.

4. Is the direction of the nails correct? Does direction of the ditch of the gear cover, match the direction of the nails? If they differ, this can cause damage. When you assemble the parts, please be careful to notice the direction of each part. Please see the drawing below for the assembly.

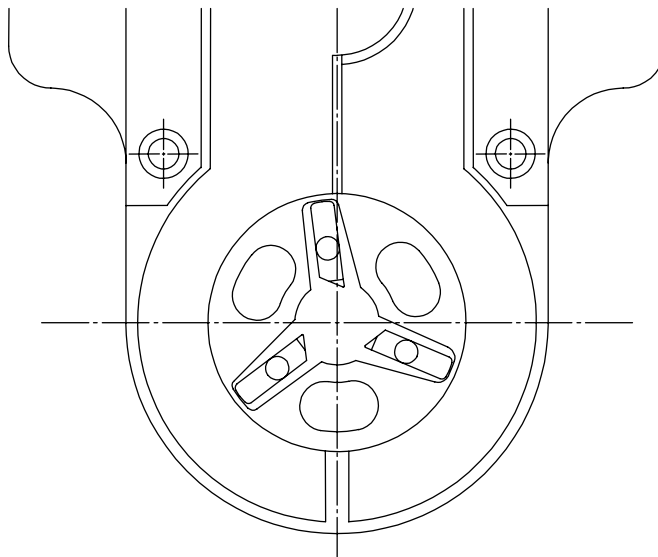

The directions of the nails to the driving gear.

5. Are there 3 nails? Are the nails damaged? When the lengths of three nails are unequal, the nail might be damaged. In this case, replacement is necessary. Please replace the nails. When replacing the nails, please replace all three of them at the same time. Please be careful to notice the directions of the gear and nails while assembling.

6. If a problem occurs for reasons other than those listed above, please contact us.

CONSUMPTION ARTICLES

1.) Parts of tip remover

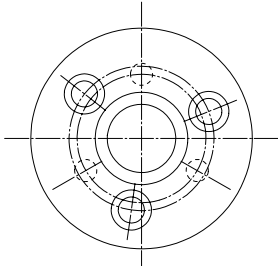
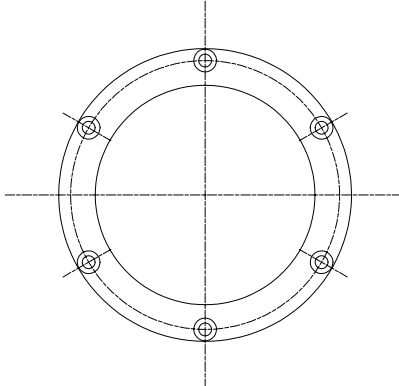
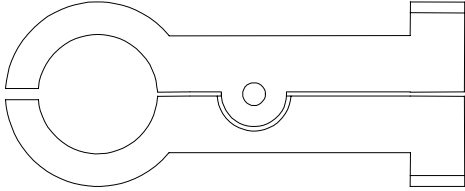
	<p>* Tip remover nail: ATCD-GA-011-1</p> <p>Quantity to replacement 3 pcs Replacement cycles 3 months</p> <p>※Drawing DH-B-F Drawing No. 000610-001-001 Number ⑫</p>
	<p>* Tip Remover Cover : ATCD-GA-009-1</p> <p>Quantity to replacement 1 set (up and down) Replacement cycles 6 months</p> <p>※Drawing DH-B-F Drawing No. 000610-001-001 Number ⑬ ⑬</p>
	<p>* Tip Remover Bushing : ATCD-GA-008-1</p> <p>Quantity to replacement 2 pcs Replacement cycle 6 months</p> <p>※Drawing DH-B-F Drawing No. 000610-001-001 Number ⑪</p>
	<p>* Tip Remover Break : ATDH-B-001-2 ATDH-B-002-2</p> <p>Quantity to replacement R/L 1 each Replacement cycle 6 months</p> <p>※Drawing DH-B-F Drawing No. 000610-001-001 Number ⑭・⑮</p>

2.) Tip setting parts

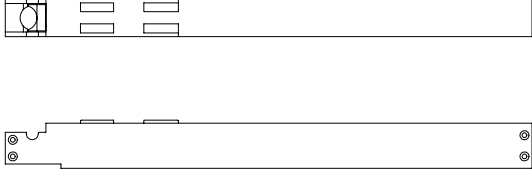
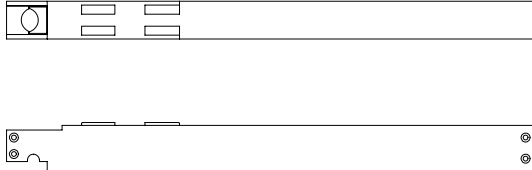
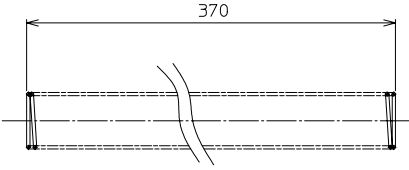
	<p>* Tip cartridge Upper (16 dia) : TS-LW-006-1 UPPER Quantity to replacement 1Set Replacement cycle Undecided</p> <p>Remarks: It is convenient to have spare cartridge for setting the cap tips out of line. You just need to change the cartridge in line.</p>
	<p>* Tip cartridge Lower (16 dia) TS-LW-006-2 LOWER Quantity to replacement 1Set Replacement cycle Undecided</p> <p>Remarks: It is convenient to have spare cartridge for setting the cap tips out of line. You just need to change the cartridge in line.</p>
	<p>* Spring for tip cartridge (16 dia) TS-SP-001 Quantity to replacement 1Set Replacement cycle 6 months</p>

REGULARLY MAINTENANCED PARTS

Maintenance Parts	Maintenance Method
Apply grease to the gear box	<p>Take off the 6pcs of M6 cap bolts to remove the upper case. Apply grease to the bushing on the gear side. Please use #2 or equivalent. Once a month. / 2g Please be careful to prevent dirt or dust from entering when opening the gear box.</p>
<p>Clean up the inner remover</p> <p>By the function, it will shave the spatter around the cap tips. This will cause damage to the nails.</p>	<p>When you move the cover without the break being applied, make sure the nails move in and out smoothly. If it is not smooth, take off the break cover (M5) and remove any build-up and make the nails move smoothly. Please be careful with the direction of the nail when assembling and prevent dust and oil on the wear side of the cover and break. Please clean up once per week.</p>
<p>Clean up the wear side of the break</p> <p>Brake and cover will wear out with use, also spatter will affect the function of the brake.</p>	<p>Make sure the nails move in and out smoothly when turning the motor with break. When it does not move smoothly or there are scratches on the tip but you cannot remove. Take off the break cover (M5) and take out the dust or oil on the break. Please avoid the dust and oil when assembling. Do not spray a lubrication onto the break system. Please clean up once per week.</p>

SH-C-F WITH STANDARD STAND

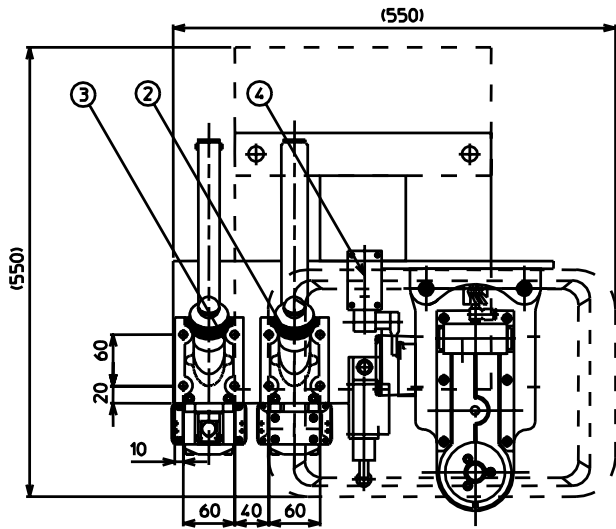

NO	ITEM	MODEL	Qty	REMARK
1	Single head remover	SH-C-F	1	
2	Tip setter (Cast type) Lower	TS-LW-L	1	
3	Tip setter (Cast type) Upper	TS-LW-U	1	
4	Original positional limit switch	WLCA2-LDAS	1	OMRON
5	Tip Bucket	K-8	1	
6	Positional limit switch for tip	WLCA2-LDAS	2	OMRON
7	Standard stand		1	
8	Power switching box for tip remover	DPS-102C	1	
9	Air 2 sets	AC2020-01G-R	1	SMC
10	Solenoid valve	VT301-015G	1	SMC

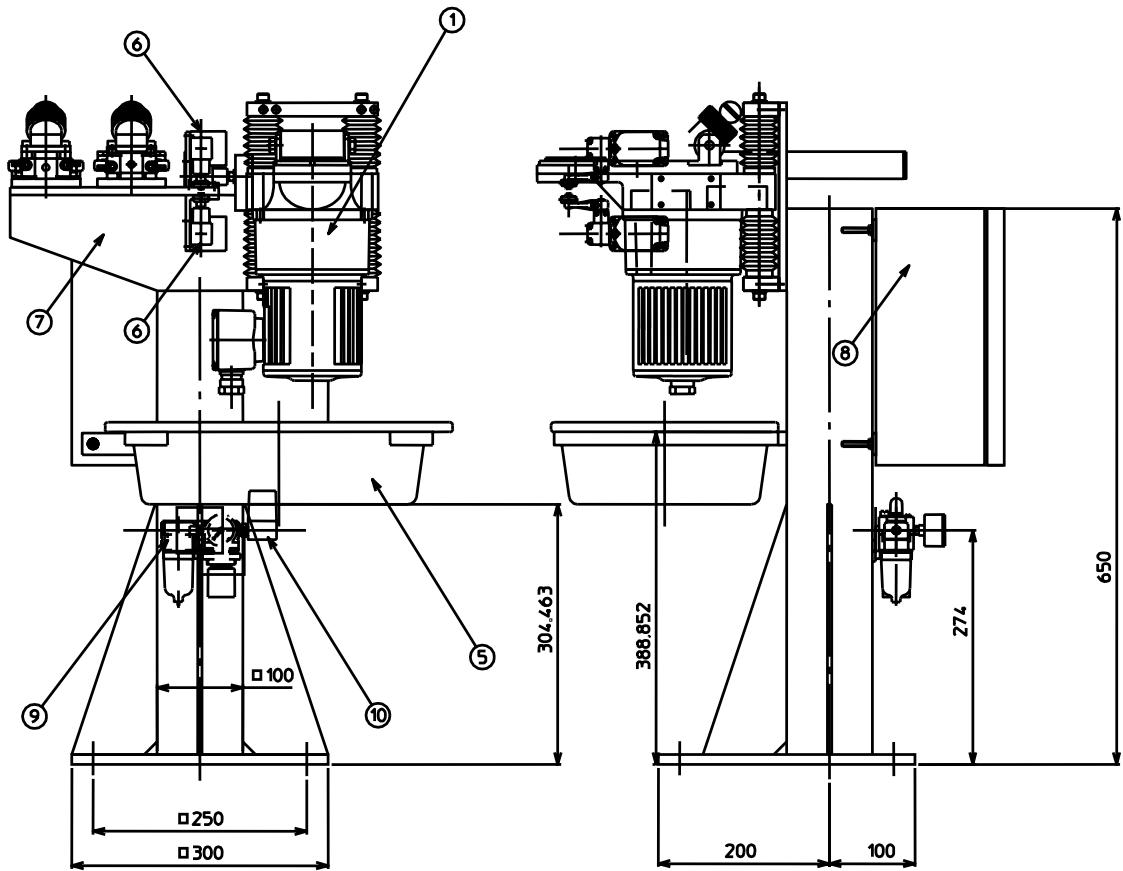

SH-C-F OUTER DIMENSIONS

ITEM	MODEL	Qty	REMARK	
1	Motor for tip remover(AC200V)	G3KM-22-60-T010A	1	
2		-	Come with motor	
3	C-type Shaft plate(Blue Metallic)	TDR-C-P-F-001	2	
4	Fix bolt for shaft plate	SUS M8×20	4	
5	Spring for C-type Lower(B)	TDR-A-P-F-003	2	
	Spring for C-type Upper(A)	TDR-A-P-F-004	2	
7	Floating shaft for C-type	TDR-A-P-F-002	2	
8	Slide bearing	SM16GWJU	2	NB
9	Bush for tip remover	ATCD-GA-008-1	2	
10	Nail for tip remover	ATCD-GA-011-1	3	
11	Cover for tip remover 16 dia Upper and Lower	ATCD-GA-009-2	1	
	Break parts for C-type R	TRE-R-P-010-1	1	
13	Break parts for C-type L	TRE-R-P-010-2	1	
14	Air nipple	KQ2V-06-01S	1	SMC
15	C-type cylinder	TRE-R-P-015-1	1	
16	Cylinder piston	TRE-R-P-014-1	1	O-ring P21
17	Plate for Original position limit sensor	TRE-R-P-20-1	1	

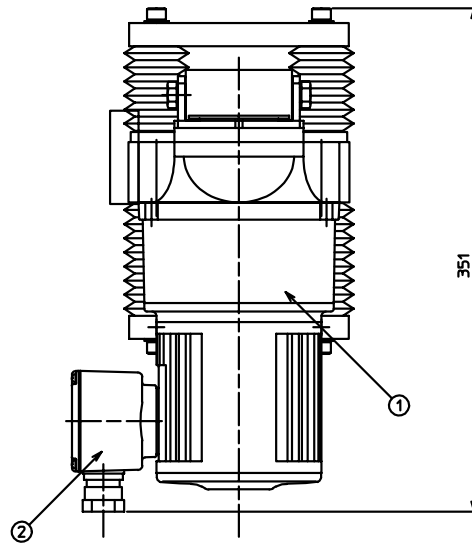
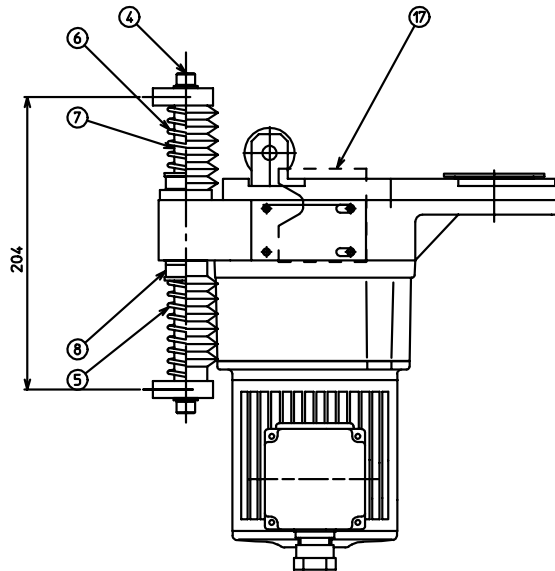
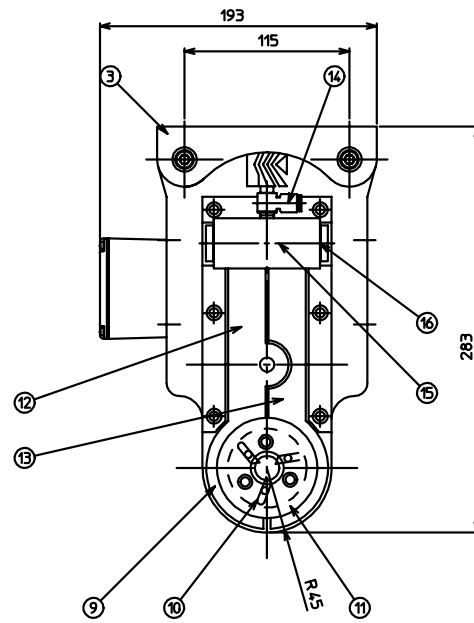

TIP SETTER OUTER DIMENSIONS

